

GENIUS VISE

pag. 5. 5

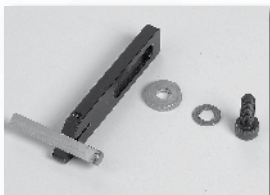

ACCESSORIES

pag. 5. 6



Spare parts

pag. 5. 10



5 ARE ITS MAIN FEATURES

1

The clamping force (up to 40 kN) is generated right where it is needed: at the part.

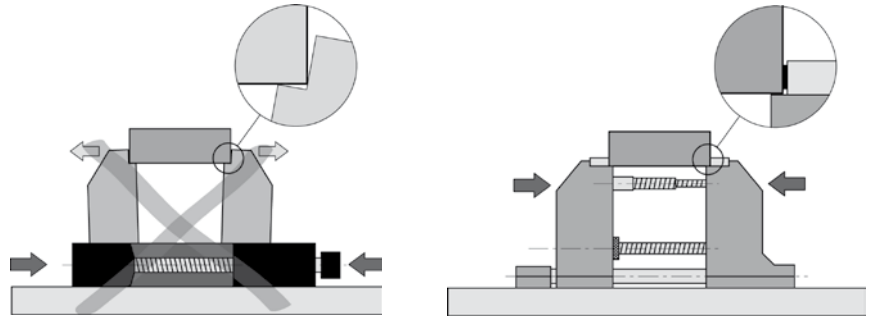

2

Thanks to its own expanding screw, GENIUS can clamp workpieces up to 200 mm with just one set-up.

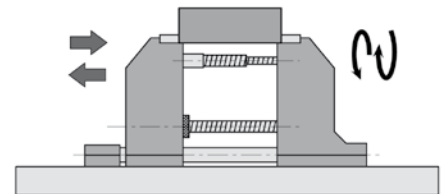

3

Unlike traditional vises, GENIUS clamps the workpieces by means of traction clamping.

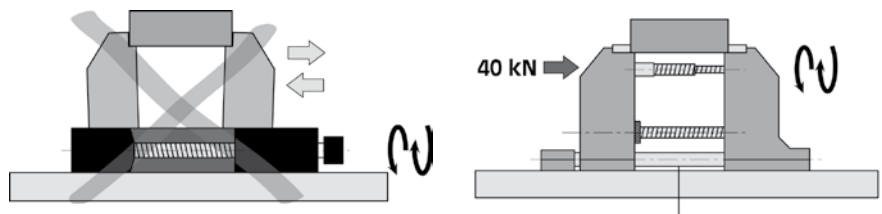

4

GENIUS is the first vise designed for 5 axis-machine tools that can be used for high precision milling operations.

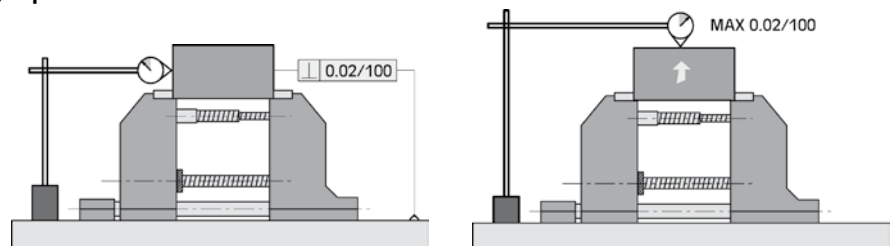

5

The movement of the jaws is not on a base, but on hardened and ground shafts. This allows for quicker and more accurate positioning of both the same axis with the centre of the machine tool pallet.

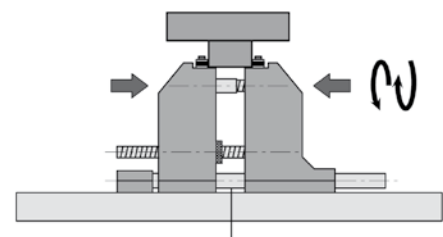

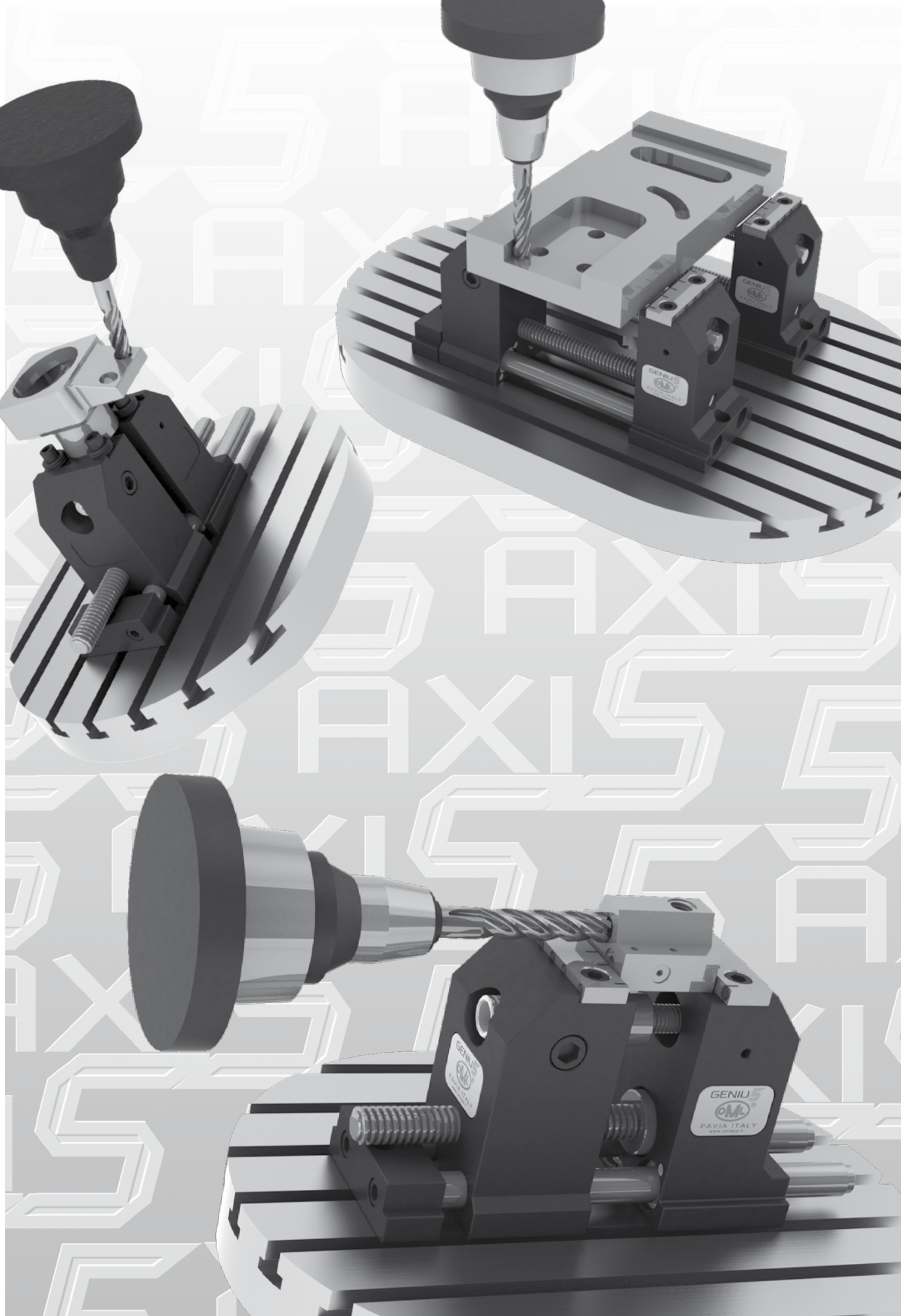

SinterGrip: the New Choice

Our new patented product **SinterGrip** is born to satisfy the current need to clamp a workpiece for very few millimeters (with SinterGrip 3,5 mm clamping surface), and this for the following reasons:

- 1) In order to machine the workpiece completely in a single operation (especially for 5 axis machines);
- 2) In order to save money for the raw materials, especially when they have a big impact on the price (aluminum, titanium, etc.)

Indirectly to these reasons, and in order to improve the performance of the machine tool and the tools

**higher cutting speed +
higher feed rate =
bigger volume of metal removed =
less time to machine the workpiece**

the market requires safe clamping, which could at the same time possibly avoid the deformations of the piece itself.

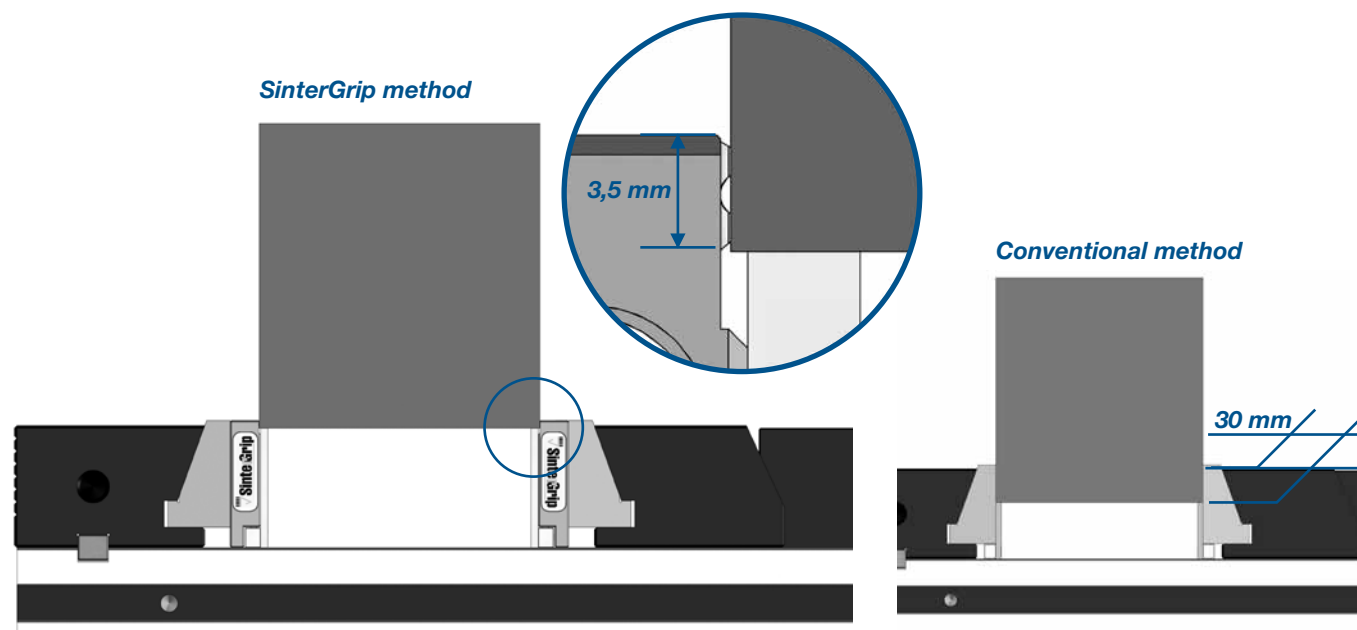

Only 3,5 mm clamping surface, no need of pre-machining the workpiece, clamping stability, higher cutting rate: SinterGrip brings only advantages compared to the traditional systems.

On the contrary, traditional systems need, for the clamping of the workpiece, a bigger clamping surface, with the result of waste of raw materials and greater possibility of deformation of the workpiece.

GENIUS vise with wrench, pair of positioning keys and Sintergrip inserts STD for steel*



* On request Sintergrip inserts HRC or inserts for ALU (see pag. S.17)

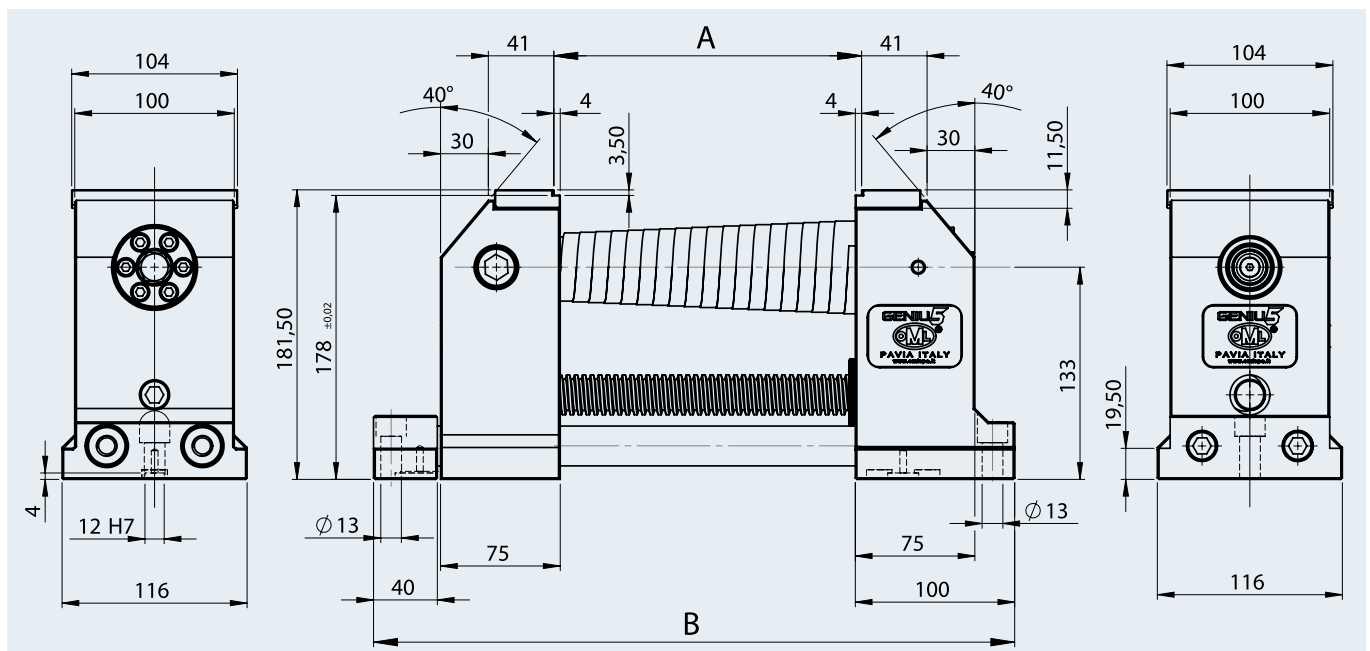

code	type	A*	B	weight kg
77 58 50 11	GENIUS 100	100	312	23
77 58 50 12	GENIUS 200	200	412	25

Special opening "A" upon request

Special applications upon request



58 50 50 00

work stop



58 50 41 19

pair of smooth/grooved jaws

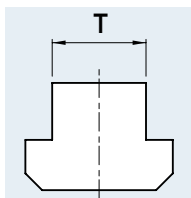

pair of clamps, complete with screw and T-nuts

		code					
mm 12	mm 14	mm 16	mm 18	mm 20	mm 22		
58 02 27 92	58 02 27 93	58 02 27 94	58 02 27 95	58 02 27 96	58 02 27 97		

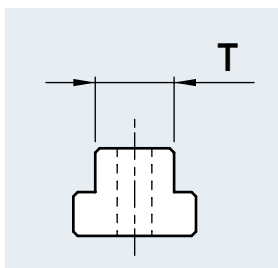

pair of nuts complete with screws M12

codice	T mm
58 50 25 93	14
58 50 25 94	16
58 50 25 95	18
58 50 25 96	20
58 50 25 97	22

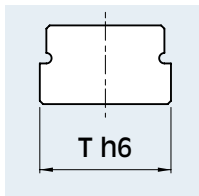

pair of positioning key

		code					
mm 12 h6	mm 14 h6	mm 16 h6	mm 18 h6	mm 20 h6	mm 22 h6		
58 01 15 92	58 01 15 93	58 01 15 94	58 01 15 95	58 01 15 96	58 01 15 97		



51 50 10 06

torque wrench

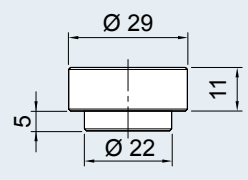

code **58 90 61 14**
set of 4 "grippers" h11 smooth

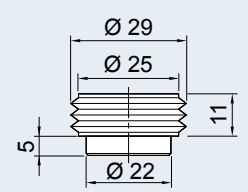

code **58 90 61 24**
set of 4 "grippers" h11 serrated

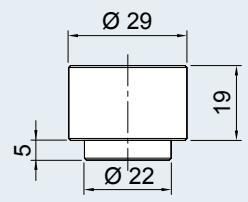

code **58 90 62 14**
set of 4 "grippers" h19 smooth

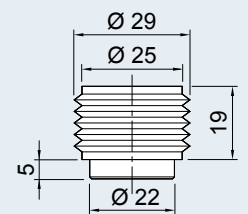

code **58 90 62 24**
set of 4 "grippers" h19 serrated

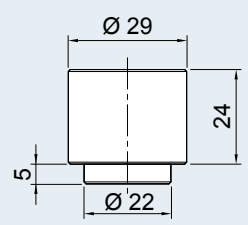

code **58 90 63 14**
set of 4 "grippers" h24 smooth

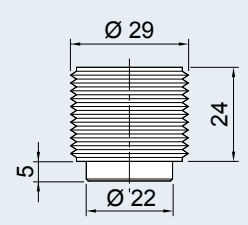

code **58 90 63 24**
set of 4 "grippers" h24 serrated

**working example with
"grippers"**



working example with SinterGrip

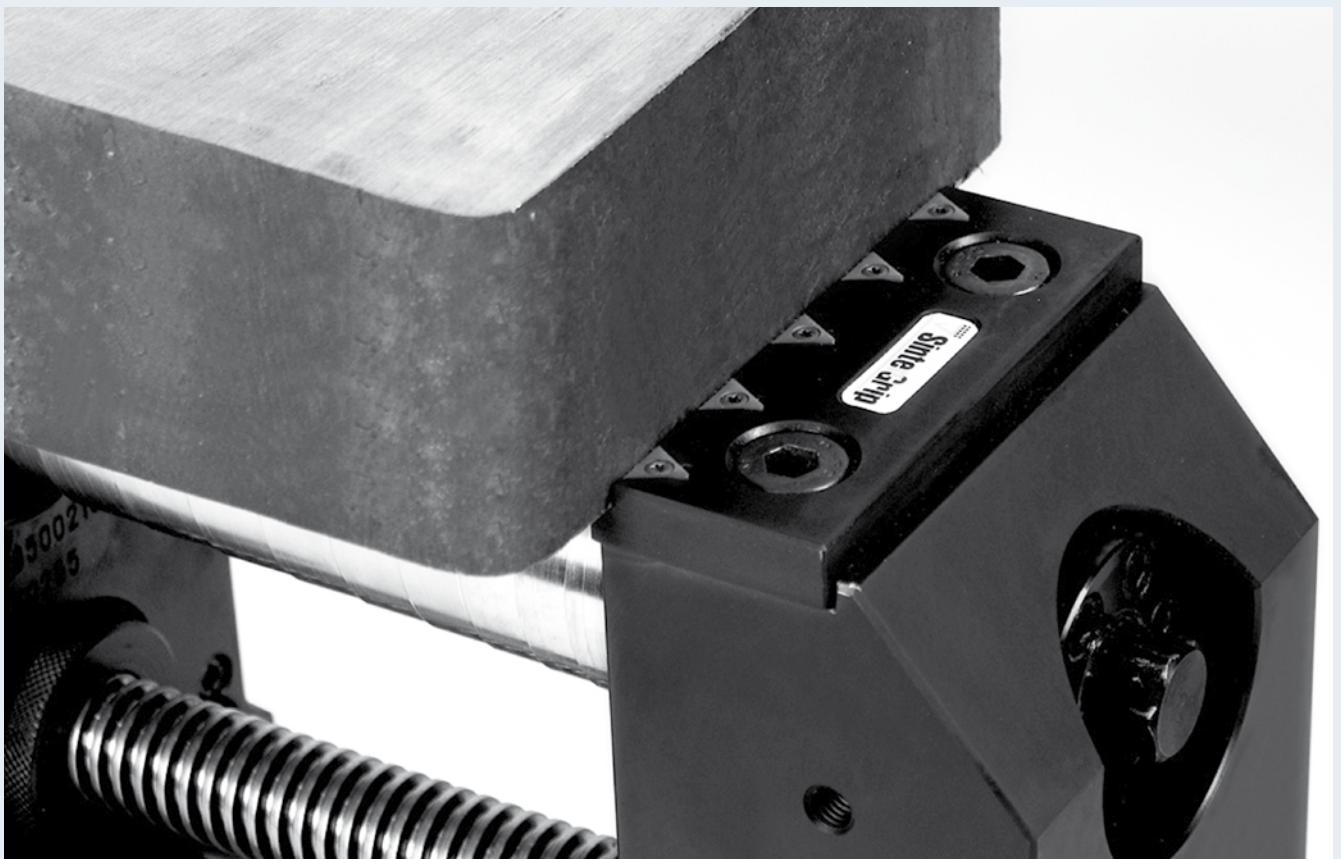

GENIU 5

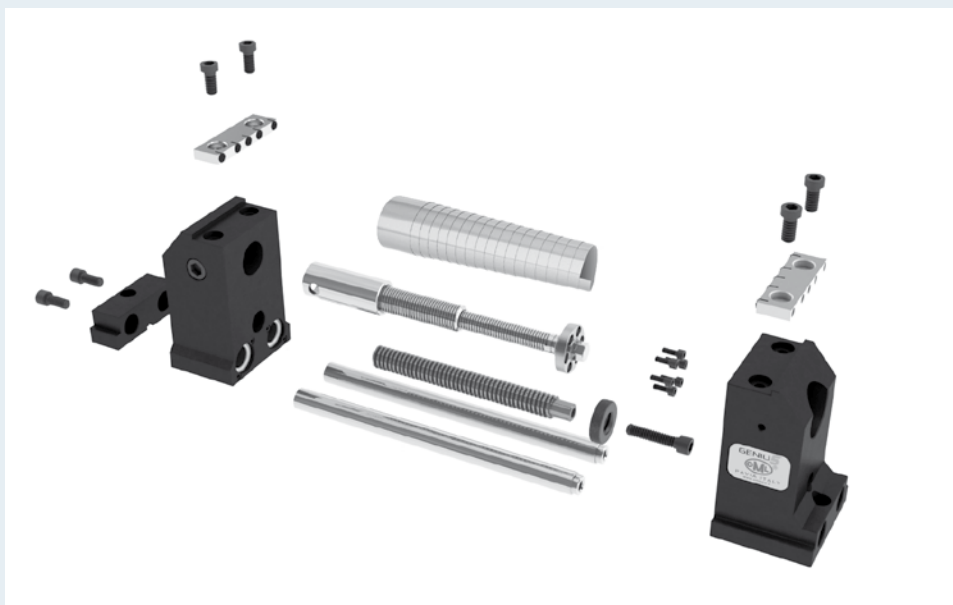
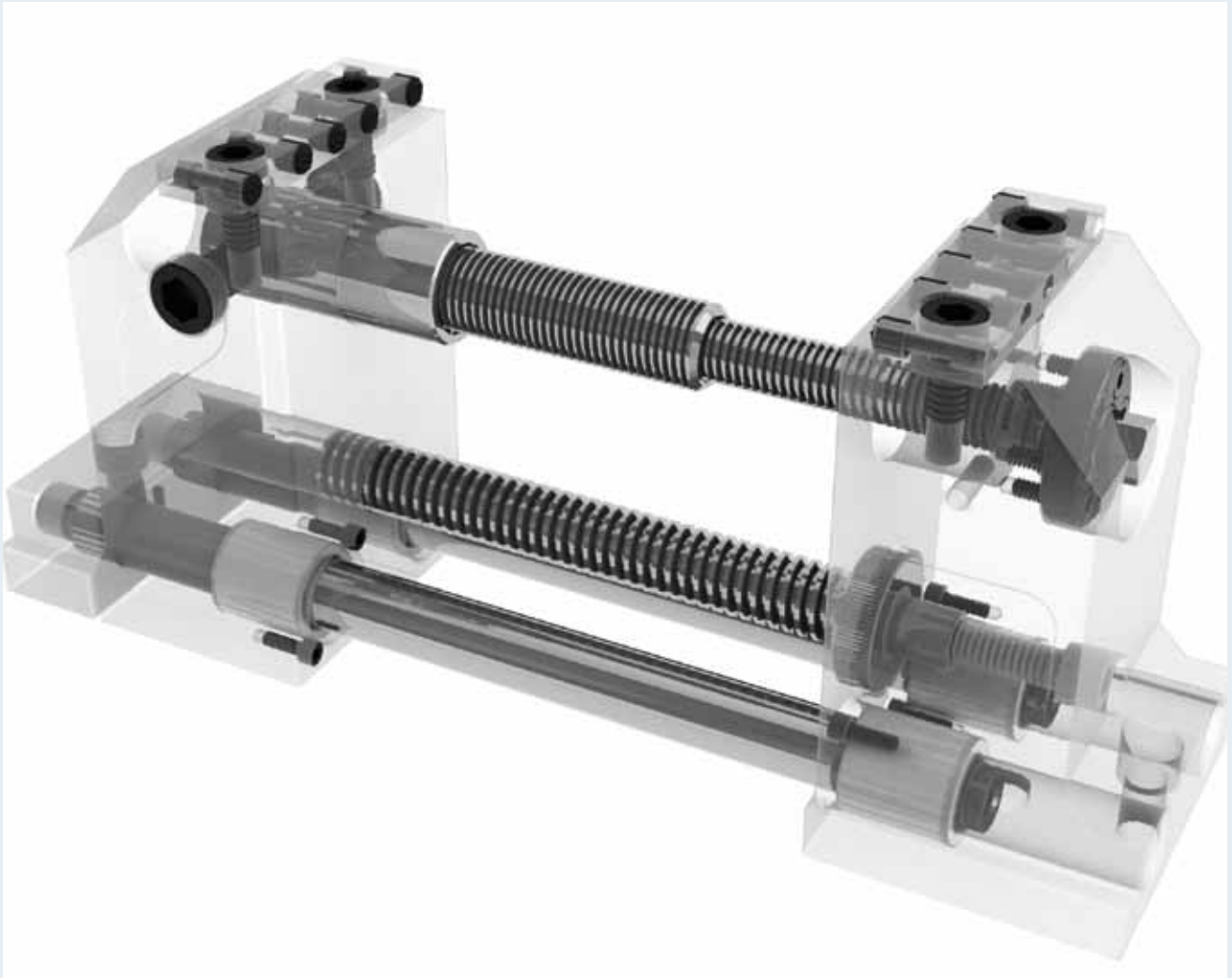



58 45 15 19

pair of jaws for Sintergrip
(Sintergrip inserts: pag. S.17)



58 50 42 19 (old)

pair of jaws with grippers



51 99 20 08 (old)

round gripper



51 50 29 10

clamping key

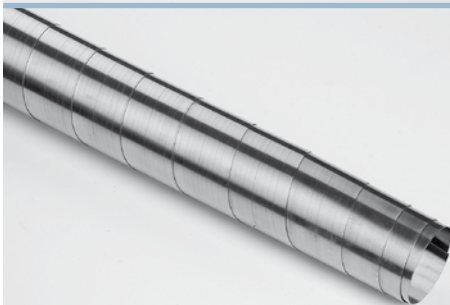

71 29 02 18

telescopic stainless steel carter



77 58 50 10

spindle group

Plate for vise GENIUS	cod.	type	weight kg
-----------------------	------	------	-----------

58 50 20 10	GENIUS 100	7
(58 50 20 20)	GENIUS 200	9

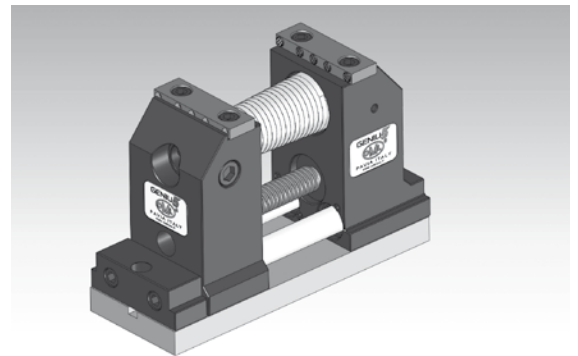
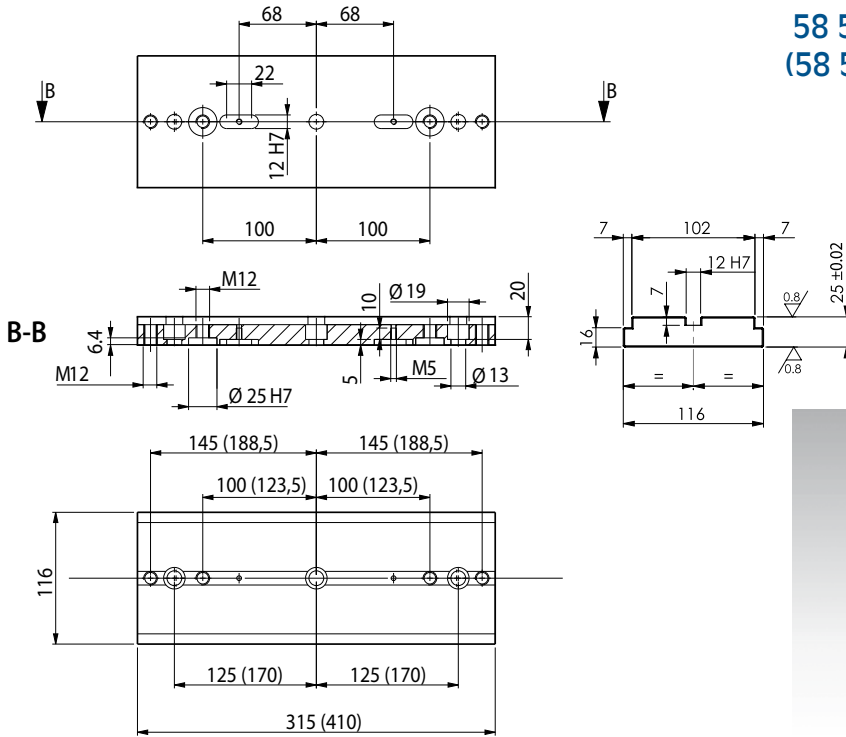

"GENIUS"

Examples of use

